

ROTATING RIGHT

ENHANCED OIL RECOVERY SOLUTIONS (EOR)



Rotating Right has provided hundreds of enhanced oil recovery solutions since our establishment. Our focus in everything that we do is creating "Value" for our customers. With our EOR solutions we bring the decades of experience in field operating, equipment service, design, and manufacturing that our people have, to every system that we build.

DESIGN INNOVATION IN FABRICATED SYSTEMS

It takes a dedicated team and solid approach to consistently provide optimized packaged pump solutions. Central to Rotating Right's focus is a commitment to creating value for our customers throughout the entire life cycle of a project, from initial design and procurement through to commissioning and long-term maintenance. Our single source approach has demonstrated reduced capital and lifetime maintenance cost through streamlined project management and optimal equipment and materials selection processes. As a full cycle provider, Rotating Right seeks to eliminate the operating downtime and start-up delays that can result from a lack of clear responsibility or communication.

We are partners in realizing our customers' goals of increased production by providing purpose built Enhanced Oil Recovery Solutions. Our ability to support customers in the field is critical in this regard, and our field experience has been firmly established, built upon the operating roots of our dedicated field service and support teams. We proficiently maintain communication throughout the company ensuring our products are built to suit the application and the operating requirements in the field. Rotating Right's comprehensive pump application expertise enables us to consistently design and deliver highly functional, user friendly and robust systems that we stand behind.

AN INDUSTRY LEADER IN THE DESIGN AND FABRICATION OF QUALITY PUMP PACKAGES & INNOVATIVE TURNKEY SYSTEMS

Rotating Right specializes in fabricated, turnkey packages. Our status as a pump distributor, pump manufacturer, and original equipment manufacturer allows us to design and manufacture virtually any type of pumping system whether it be a simple pump skid or a complete pump package including controls, accessories and buildings designed to meet your specifications.

We believe that the main factor that sets us apart from other companies is that we are not just a pump distributor, or a package fabricator, or a pump service company, we are all three, and more! Rotating Right offers the technical know-how to confidently assist in the design of your system and the resources to see your project through from defining the application to commissioning and start-up.



COMPLETE TURNKEY EOR SOLUTIONS

Rotating Right fabricates a full range of mechanical and process packages including stand-alone pump skids to modular sub-assemblies and fully-functional equipment skids.

- Experienced applications & drafting personnel
- Millwright supported design process
- P&ID development
- 3D CAD modelling of complete system
- ASME B31.1 and B31.3 certification
- Trained and certified personnel
- Externally audited HSE program
- Certificate of Recognition for safety from Alberta Government

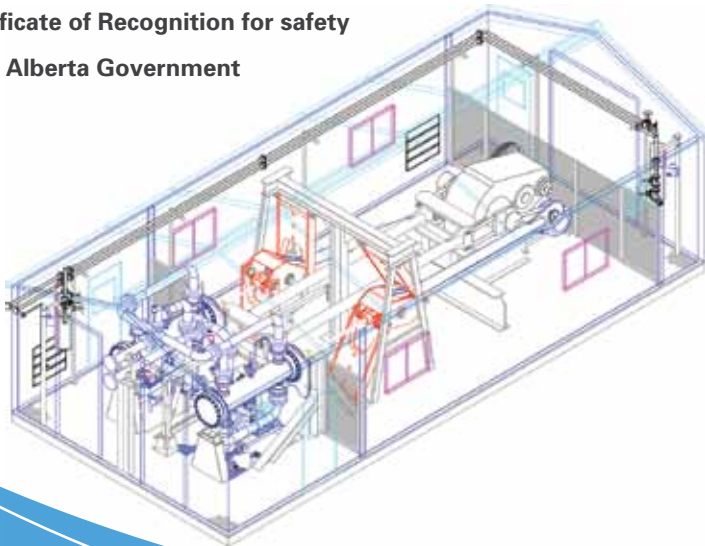

Fabrication Policies

- Superior quality control procedures
- Standardized fabrication procedures
- Continuous improvement
- An environment optimized for production
- A manufacturing approach to fabrication
- Accurate productivity measures
- Efficient material storage and control

RECIPROCATING PUMPS

Rotating Right's personnel have decades of experience in the application and service of reciprocating pumps. Rotating Right has access to a wide range of reciprocating plunger and piston pumps and we have used pumps from National Oilwell, Weatherford, Gardner Denver, Ajax, Union, Wheatley, SPM and others to design purpose built solutions ranging from 1hp to 1600hp for our customers.

We have designed and manufactured solutions for water injection, water disposal, polymer injection, chemical injection, lease automatic custody transfer (LACT) units, LPG/LNG pumps, pressure testing, jet pumping, plant wash-down and others.



HORIZONTAL PUMPING SYSTEM (HPS)

CONVENTIONAL HPS

The HPS provides a low maintenance and cost effective solution for a range of fluid handling requirements. This product line consists of a range of horizontally-mounted multi-stage centrifugal pumps which are designed for high pressure and medium flow rates and are suitable for a range of heavy-duty industrial applications.



Each HPS unit is securely mounted on a heavy-duty oilfield skid and consists of a prime mover (typically a two-pole electric motor or diesel engine), thrust chamber, intake assembly, horizontally mounted multi-stage pump and discharge head.

Since the development of the horizontal surface pumping system in the mid 1980s, the design has proven to be a cost-effective alternative to split case, turbine, and positive displacement pumps. When compared to these alternate pump types, HPS offers high reliability, reduced capital cost, design flexibility, timely delivery, and minimal maintenance.

ROTATING RIGHT HPS DESIGN ADVANTAGES

Our system is a total redesign from all the typical HPS currently on the market. The majority of the multi stage centrifugal units currently available are an extension of downhole ESP designs. They utilize staging and standard pump diameters originally designed for downhole applications, resulting in size limitations due to casing diameters.

The Rotating Right HPS was designed and built specifically for surface applications. It utilizes large diameter impellers enclosed in a 19.5" housing that cover a wide range of flow rates and differential pressure requirements. This allows us to reduce the overall footprint of the system and create a more robust design with increased reliability.

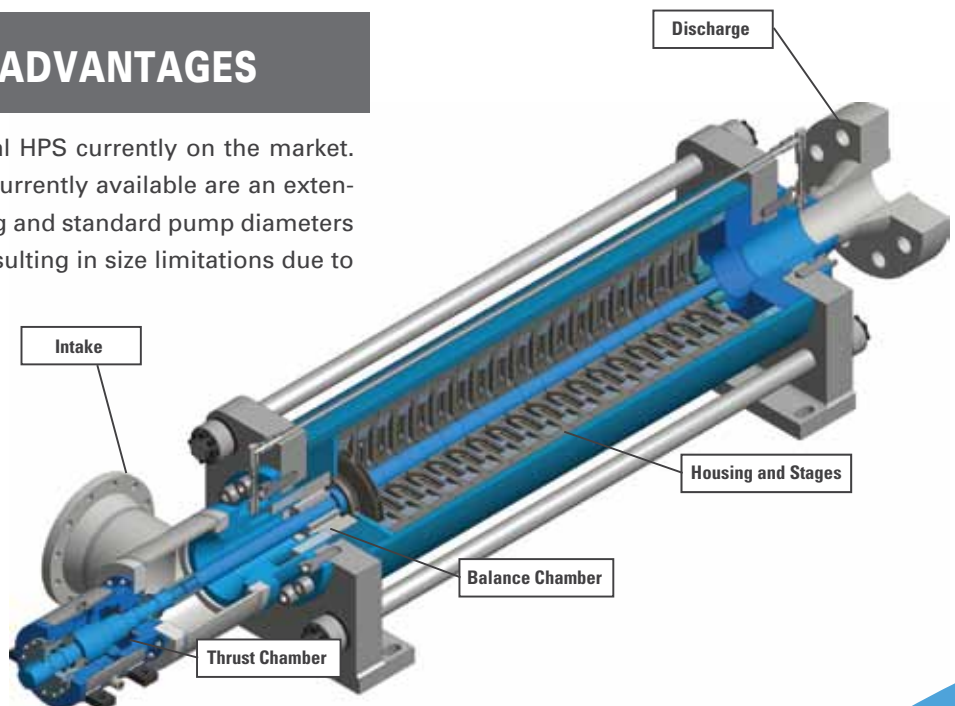

In our standard package, the pump barrel is 1.75m in length. This housing can accommodate six different sizes of staging without changing any outside components. For example, a system that was designed to produce 1800m³/day at a differential pressure of 34.5MPa could be changed to a unit that produces 4560m³/day at a differential pressure of 17.65MPa by simply replacing the internal stages. This flexible design covers 300-2000hp applications with the same housing, base and thrust chamber with minimal change to the footprint of the system (should larger motors be required).

A balance chamber is included in Rotating Right's design which eliminates the thrust load that is generated by the pump and ensures that an optimal load is placed on the thrust chamber. This load can be electrically controlled and monitored through Rotating Right's VFD (with Smooth Operator), control valves, pressure transducers, and load cells.

Typical 675 series HPS design
vs
Rotating Right RR75-205-9 capable of producing
1800m³/day at ~18MPa differential pressure

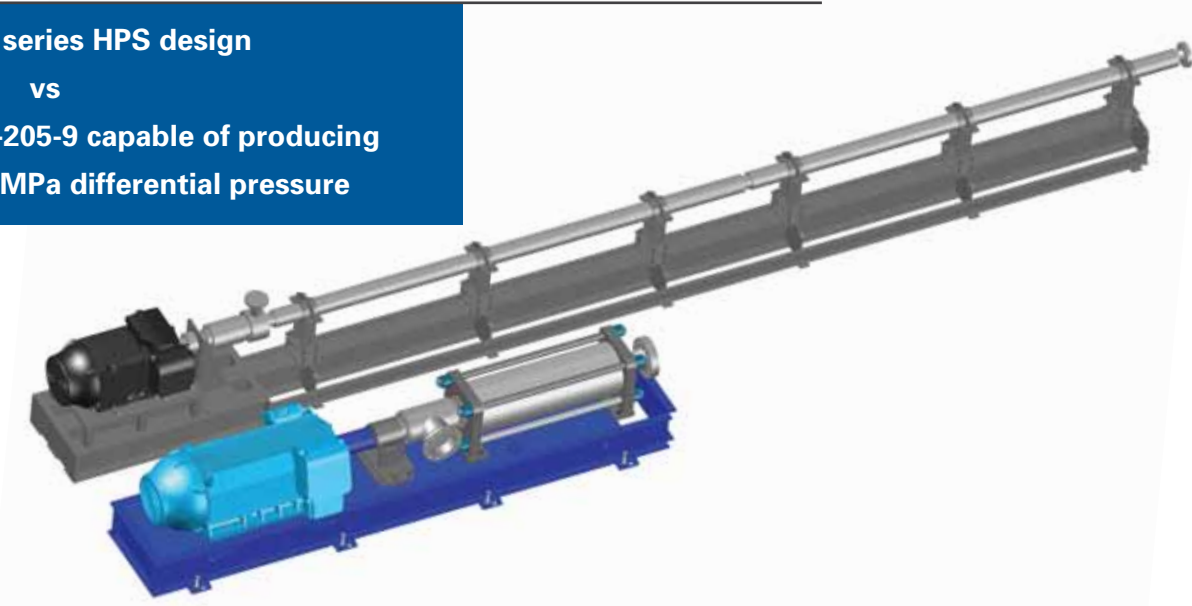

Rotating Right HPS Pump Stages

Pump Series	Flow Rate m ³ /day	Maximum Pressure (MPa)
RR75-205	1800	34.5
RR95-205	2280	34.2
RR115-205	2760	30.3
RR140-205	3360	25.7
RR165-205	3960	22.2
RR190-205	4560	19.6

Rotating Rights standard product line includes:

- Wear rings on each stage
- Balance chamber designed to remove the majority of the pump thrust, reducing the overall load on the thrust chamber and resulting in a more reliable system
- Skid designs covers 300 - 2000hp
- Local design and manufacturing
- Small foot print
- Precision machined, heavy wall pump

A range of instrumentation and monitoring options are available for the HPS. These options can be monitored and controlled remotely through Rotating Right's Smooth Operator. These options include pressure transducers, oil and bearing RTD's, oil level sensors, load cells (for thrust loads), vibration transmitters and flow meters.

Packaged HPS units housed in prefabricated buildings and delivered to the site are available as complete turn-key systems. By purchasing from a qualified and experienced single-source vendor, the design, review, and inspection process can be significantly streamlined. In addition, Rotating Right can pre-test the complete package, improving reliability and start-up performance.

Thousands of HPS units are operating around the world in applications as diverse as:

- Water flooding
- Brine disposal
- Mine dewatering
- Crude oil and NGL transfer
- Amine circulation systems
- Power fluid pressurization for subsurface jet pumps
- CO² sequestration

Every Rotating Right HPS unit is designed, assembled, and tested to stringent standards at our manufacturing and test facility in Leduc, Alberta, Canada.

ROTATING RIGHT HPS PERFORMANCE RANGE

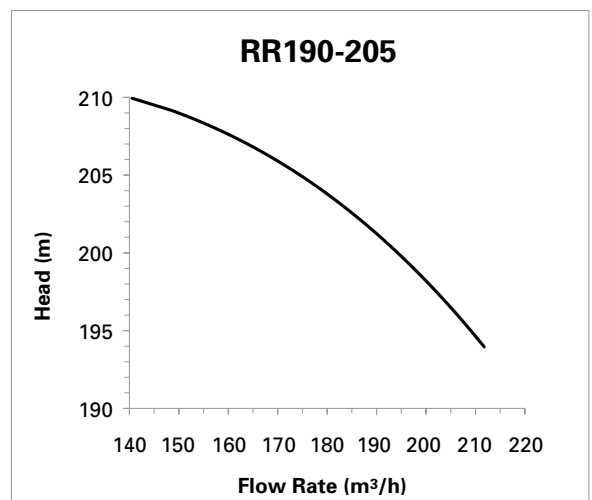
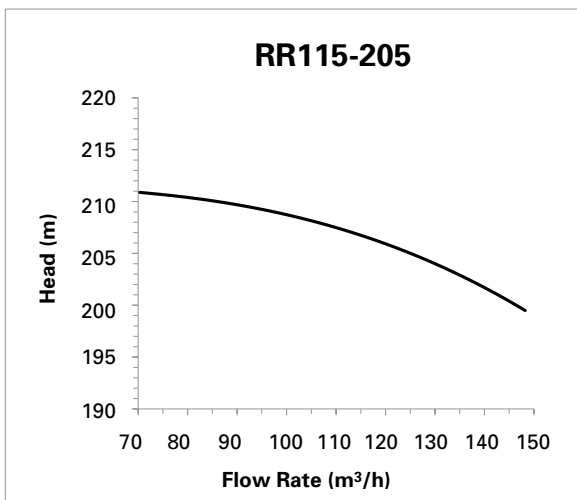
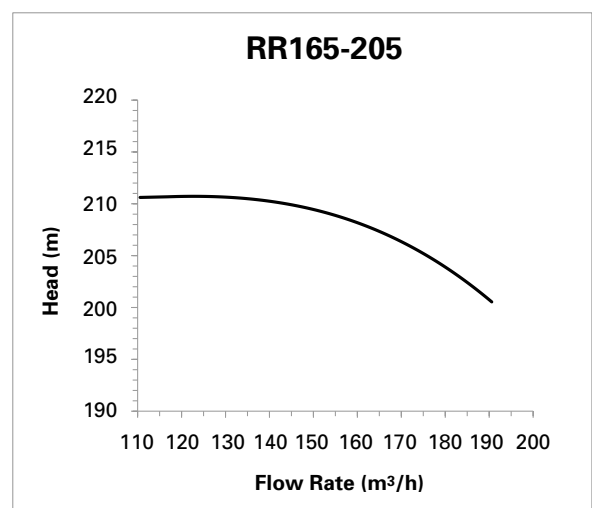
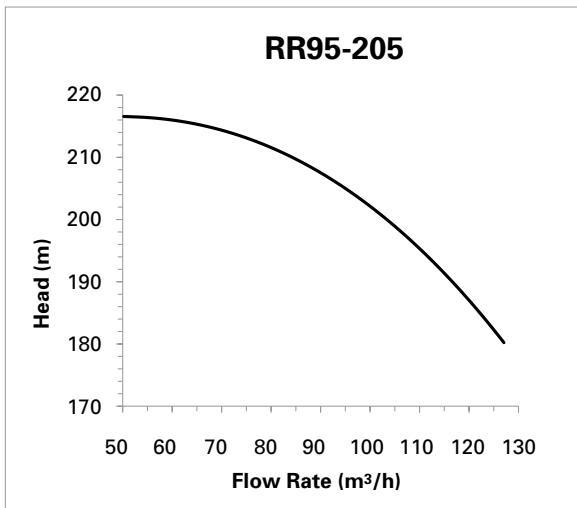
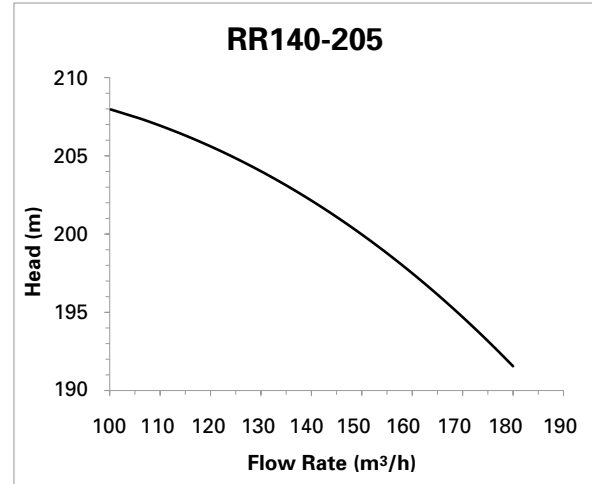
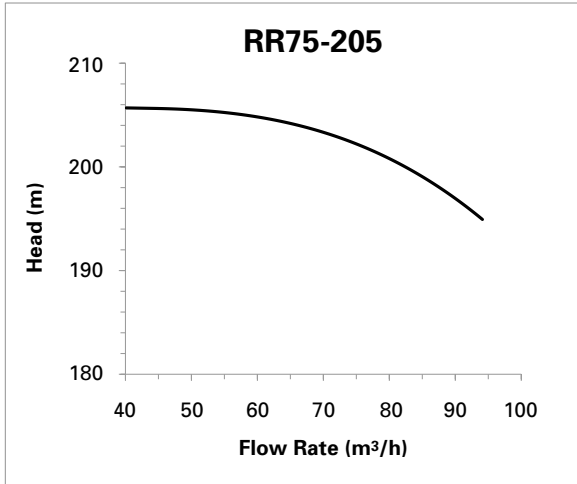

Above curves are based on pumping water at 70 degrees Fahrenheit and a specific gravity of 1.0.

Curves show single stage performance only.

FLUID TRANSFER PUMPS

CENTRIFUGAL

Rotating Right offers sales, service, and application support for centrifugal pumps including industrial pumps, ANSI Pumps, API 610 Pumps, Vertical In-Line and Mag Drive pumps. We have provided pumps for many applications including water transfer and boosting, oil transfer, glycol, amine and condensate service. Centrifugal pumps can be used in the toughest environments including sour applications, high chlorides, high temperature and low NPSH conditions.

PROGRESSING CAVITY

At Rotating Right, we have found that Progressive Cavity Pumps are the most versatile pumps in the industry for tough applications, from sand to solids, to multiphase liquids. In past installations we have found success with progressing cavity pump in many applications such as:

- Slop Oil
- Annulus Gas Condensate
- Oil Water Emulsions
- Fermented Primary Sludge
- Alum Metering
- Drilling Fluids
- Ammonium Hydroxide
- Flocculent Metering
- Bitumen Truck Unloading
- 4 - 5% Biological Sludge
- Animal Fat / Tallow (Bio-Diesel)
- Waste Activated Sludge (WAS)
- Zinc sulphate/ammonium sulphate
- Thickened Waste Activated Sludge (TWAS)
- Polymer - Chemical Injection/metering
- Liquid Chlorine Injection/metering
- Soda Ash
- Sales Oil Transfer
- Oil Recycle Pumps
- Oil Loading / Unloading
- Glycol Transfer
- Skim Oil Pumps
- Treater FWKO Pumps
- IGF Skim Pumps
- PG Condensate Pumps
- Heavy Oil Transfer

TWIN SCREW PUMP

Twin screw pumps are excellent for loading and unloading because of their ability to pump highly viscous fluids and their effectiveness when utilized in heavy crude oil and crude oil/ water emulsion applications. Unlike reciprocating pumps, they have extremely low shear and pulsation and do not require pulsation dampeners. They are a great fit for flow and pressure applications that fall between centrifugal and reciprocating pump capabilities.



METERING AND DIAPHRAGM

At Rotating Right, when applications lead us outside of our standard product lines, we work with suppliers that have specialized pumps for specific applications. Our applications team have experience with chemical injection pumps, high pressure diaphragm pumps, gear pumps and rotary vane pumps for pumping anything from propanes, butanes, demulsifiers, inhibitors, and other.

MULTIPHASE PUMPS

Rotating Right has many years of experience designing, manufacturing and applying complete multiphase solutions. We offer the broadest range of multiphase products on the market, allowing us to provide the best fit for purpose solutions.

MULTIPHASE TRANSFER PUMP (MTP)

Rotating Right's MTP is a duplex, double-acting piston pump that is capable of handling up to 250,000 BOEPD of water, oil and gas mixtures. Our pump can handle up to 99.5% Gas Volume Fraction (GVF) continuously, it can operate at 100% GVF intermittently. This pump can be designed up to 700 PSI differential pressure and up to 1,440 PSIG working pressure. Our design enables the pump to operate at a very low speed; less than 15 RPM as well as handle solids, high temperatures and high amounts of H₂S. Our housing, pistons and liners can be made from a variety of materials to suit any pumping application. The shaft sealing is a practical and simple design that is used on critical wells globally.



MULTIPHASE PROGRESSIVE CAVITY PUMP

Our knowledge of multiphase pumping supports our ability to recommend the equipment best suited for the application. Progressive cavity pumps offer versatility and can be used in almost all branches of industry. Their pumping capabilities range from pumping low-viscous to high-viscous media with or without solids with differential pressures up to 350 psig with a flow rate below 150,000 BOEPD per pump. They can also be supplied with various rotor/stator geometries. With proper application, the progressive cavity pump allows for smoother operation, improved efficiency and increased service life making them the most cost effective form of multiphase pumping available.

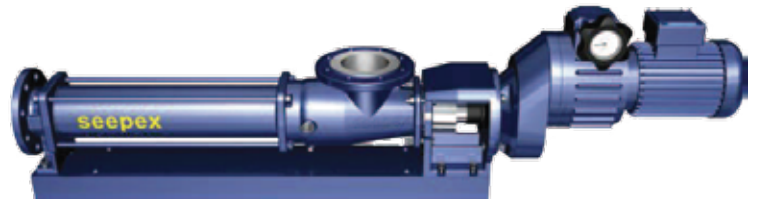

MULTIPHASE TWIN SCREW PUMP

Twin screw pumps were first tested for use in multiphase applications in 1989 and are one of the most widely used type of pump for these applications. We offer twin screw multiphase packages that cover a range of 10,000-170,000 BOEPD at up to 750 psi differential pressure.

ARTIFICIAL LIFT

RECIPROCATING ELECTRIC SUBMERSIBLE PUMP (RESP)

With Rotating Right's RESP, a linear motor replaces both pump jack and sucker rods to drive a reciprocating pump end to lift production to surface. The pump and linear motor are run on the end of tubing with power cable from surface banded to tubing as in conventional ESP installations. The Smooth Operator controller energizes the motor only when travelling up or down and the motor is off between strokes which saves energy. The stroke rate is highly adjustable and the entire system can be monitored and controlled remotely. This is a revolutionary improvement over the conventional reciprocating pump technology used in the industry for over a century.

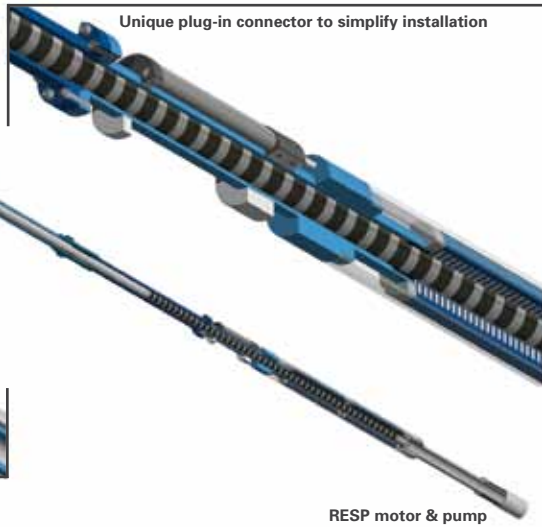

Close valve spacing to maximize compression

RESP motor & pump

JET PUMP

With jet pump systems, a well's own produced oil or water is recycled to use as the power fluid. Specific surface and subsurface equipment is essential for a complete system. The subsurface jet pump is what transfers energy and momentum, mixing the power fluid with the well fluid to produce the combined fluid to the surface. In order to condition, clean and pressurize the power fluid, well-designed and manufactured surface equipment is required.

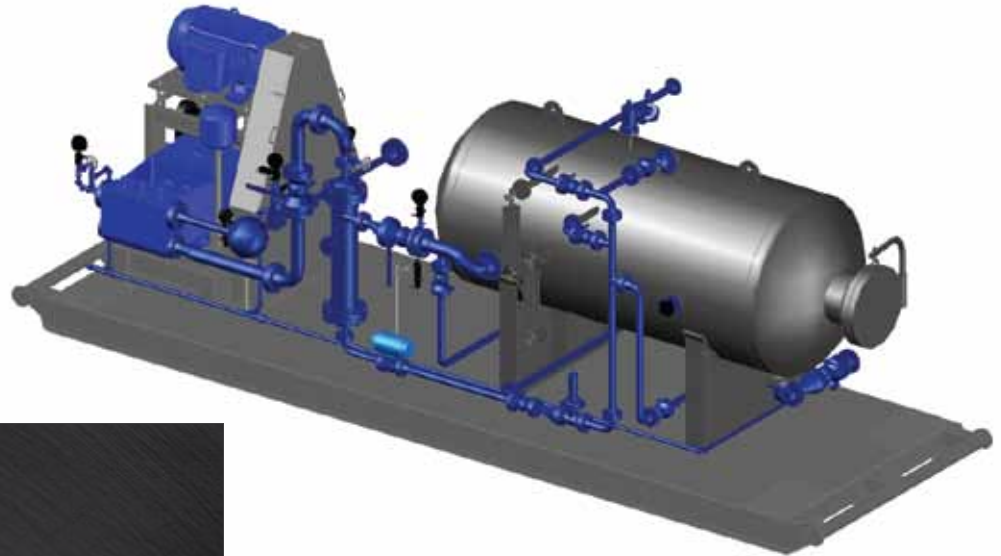

ELECTRICAL

MOTORS

We utilize quality products that meet or exceed the highest international standards and specifications in all of our solutions. As with pumps, our status as an OEM gives us access to a wide range of high quality electric motors from a global manufacturing base which allows us to select motors that provide the most value for our customers.

VARIABLE FREQUENCY DRIVES (VFD)

We believe that using a VFD for motor control increases flexibility, provides more options for automation and improves motor life. Our experience in using VFDs in many different applications gives us the knowledge to ensure that the complete system will operate smoothly and trouble free in the application and environment it was designed for.

Advantages of using VFD

- Increase efficiency of AC Motor
- Lower in-rush current of AC Motor (Soft Start)
- Lower mechanical stress on AC Motor and process
- Energy Savings on Variable Torque Loads (Centrifugal Fans or Pumps)
- Eliminate need for throttling valves or dampeners and reduces maintenance costs
- Extended equipment life
- Process improvement in acceleration, flow, monitoring, pressure, speed, temperature, tension & torque
- Single to three phase conversion
- Flexibility to run multiple motors with one VFD

SMOOTH OPERATOR

Advanced monitoring and Control

Rotating Right's Smooth Operator is our solution to providing intelligent control with programmable logic to all of the enhanced oil recovery systems that we manufacture. We have given our customers the ability to have 24/365 monitoring of conditions equipment reducing human intervention. The Smooth Operator Controller can be programmed to monitor and control motor speed, discharge pressure and flow rates, pump vibration, thrust load on thrust chamber, bearing and oil temperatures and intake pressure and flow rates. It effectively monitors for conditions that could result in costly catastrophic failures and will shut down equipment before it occurs. The user friendly graphical display enables operators to monitor and program the system operation locally or the system can be accessed remotely via SCADA.



Features and Benefits:

- Automation of systems
- Continuously monitors pump conditions and shuts down pump if adverse conditions are detected
- Touchscreen display provides HMI (Human Machine Interface) for local control, analysis and configuration
- Continuous logging and monitoring of all on-site equipment. Minimum 60 days historical data
- Optional remote monitoring and control. Exceptions/alarms may be immediately transmitted to an operator's cell phone or email
- Three levels of password-protected security
- Easily customizable User Interface Screens
- Graphing and trending module for quick, at-a-glance performance analysis
- Convenient configuration upload/download via USB
- Feature enhancement via automated USB firmware upload
- Optional Asset Management Module to track and manage your remote assets

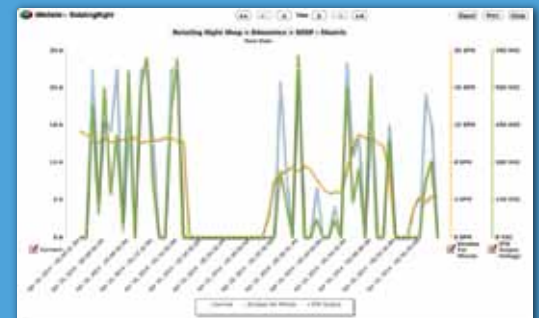

ACCESSORIES

Rotating Right offers a full line of accessories to ensure long, trouble free and safe operation of your pumping systems.

FILTRATION SYSTEMS



We provide a variety of filters including bag filters, cartridge filters, media filtration and disposable filters. Each of our filtration products are available as single units or complete skid-mounted high or low pressure filter packages.

PULSATION EQUIPMENT



The application of pulsation equipment helps provide optimal results for many pumping systems, our distribution access to many makes of pulsation equipment allows us to supply the most efficient.

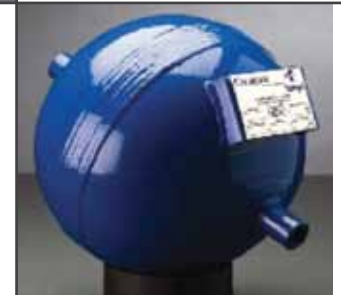

INSTRUMENTATION

Whether it is a simple pressure gauge or a fit for application pressure control valve, Rotating Right's experience with pumping solutions, allows us to work with industry leaders of instrumentation and controls to create a system that meets every requirement.

- **Vibration Shock Switches & Transmitters**
- **Liquid Level Gauges, Switches & Transmitters**
- **Pressure Safety Valves & Pressure Relief Valves**
- **Pressure Switches & Transmitters**
- **Flow, Pressure and Level Control Valves**
- **Flow Meters (turbine, coriolis & mass)**
- **Temperature Switches, Thermowells & Transmitters**



SERVICE

At Rotating Right, we believe that our commitment to the full circle approach to servicing the equipment we supply is what differentiates us the most from our competition. Decades of combined pumping experience allows us to offer the proper product for the application and effective technical and troubleshooting assistance when needed. We offer field experts on call with fully equipped mobile field service units available 24 hours a day, 7 days per week for support and service.

We use the Service Manager program for accurate record keeping and data storage to provide our customer and our team with a detailed summary of all historical maintenance and service performed on their equipment.

As a company, Rotating Right is committed to support our customers through installation, maintenance and start-up of systems. We offer annual maintenance contracts as an option to keep everything running smoothly. We carry a range of high quality parts in our inventory to ensure efficient replacement if needed.

Rotating Right offers a reciprocating positive displacement pump diagnostic service with direct readout of pump performance and piping system response to determine the root cause of any reciprocating pump system problem.

Our service technicians follow strict quality control procedures for every pump repair, recondition and overhaul. The use of consistent and reliable re-manufacturing techniques ensure the equipment is returned to back to you in "like new" condition.



PARTS INVENTORY

Rotating Right provides a wide range of replacement parts for any pumping system. Our inventory includes plungers, packing, stuffing boxes, valves, bearings, crankshafts, connecting rods, impellers, shafts, mechanical seals, rotors, stators, flex joints, gaskets and seals.



CERTIFICATIONS



The Pressure Equipment
Safety Authority



www.rotatingright.com
Phone: 780.485.2010
Fax: 780.485.1938

